

Cladding

CLADDING - PINE

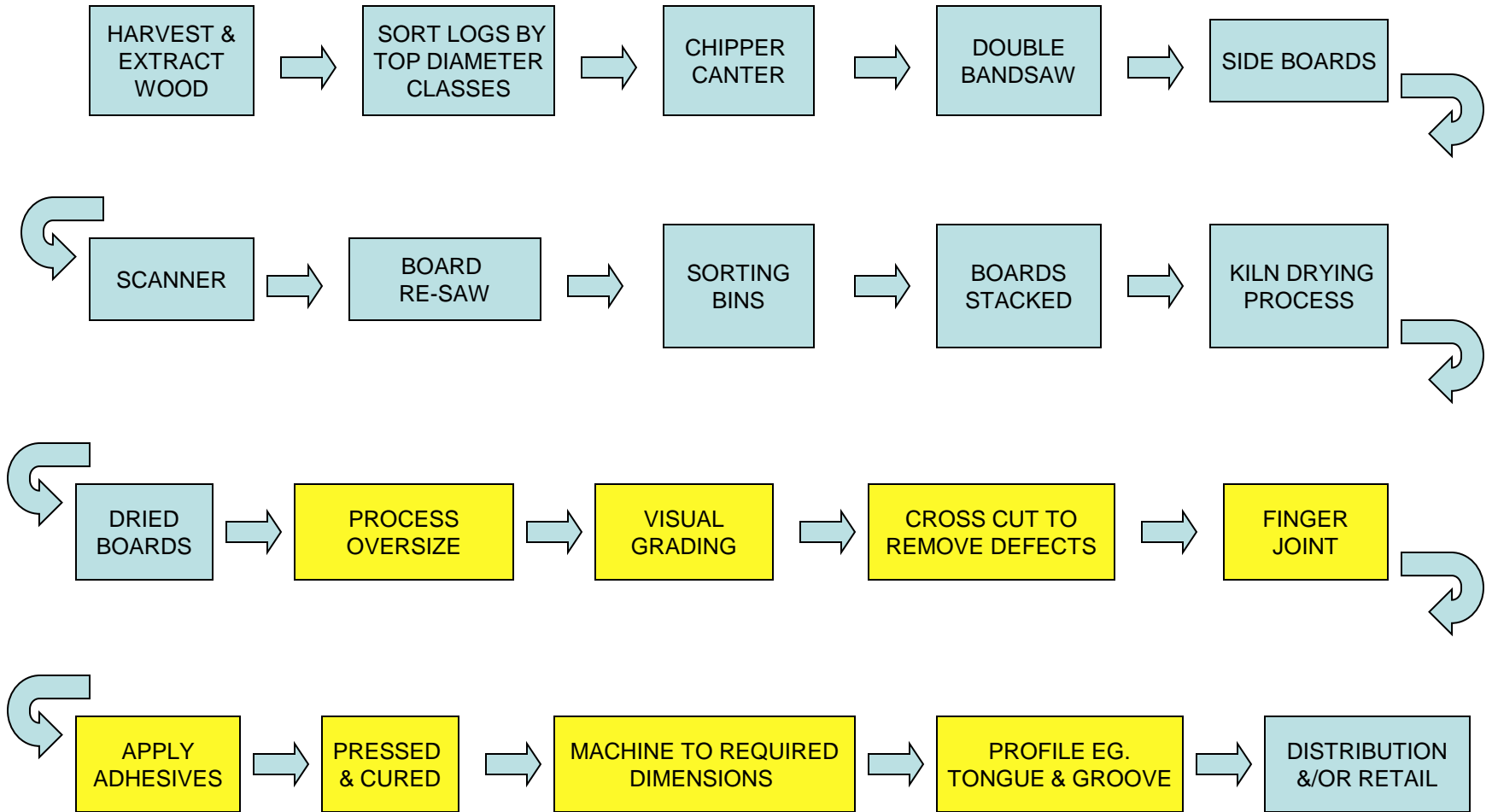

EXCLUDES CO - PRODUCTS & RESIDUES

Defect Removal

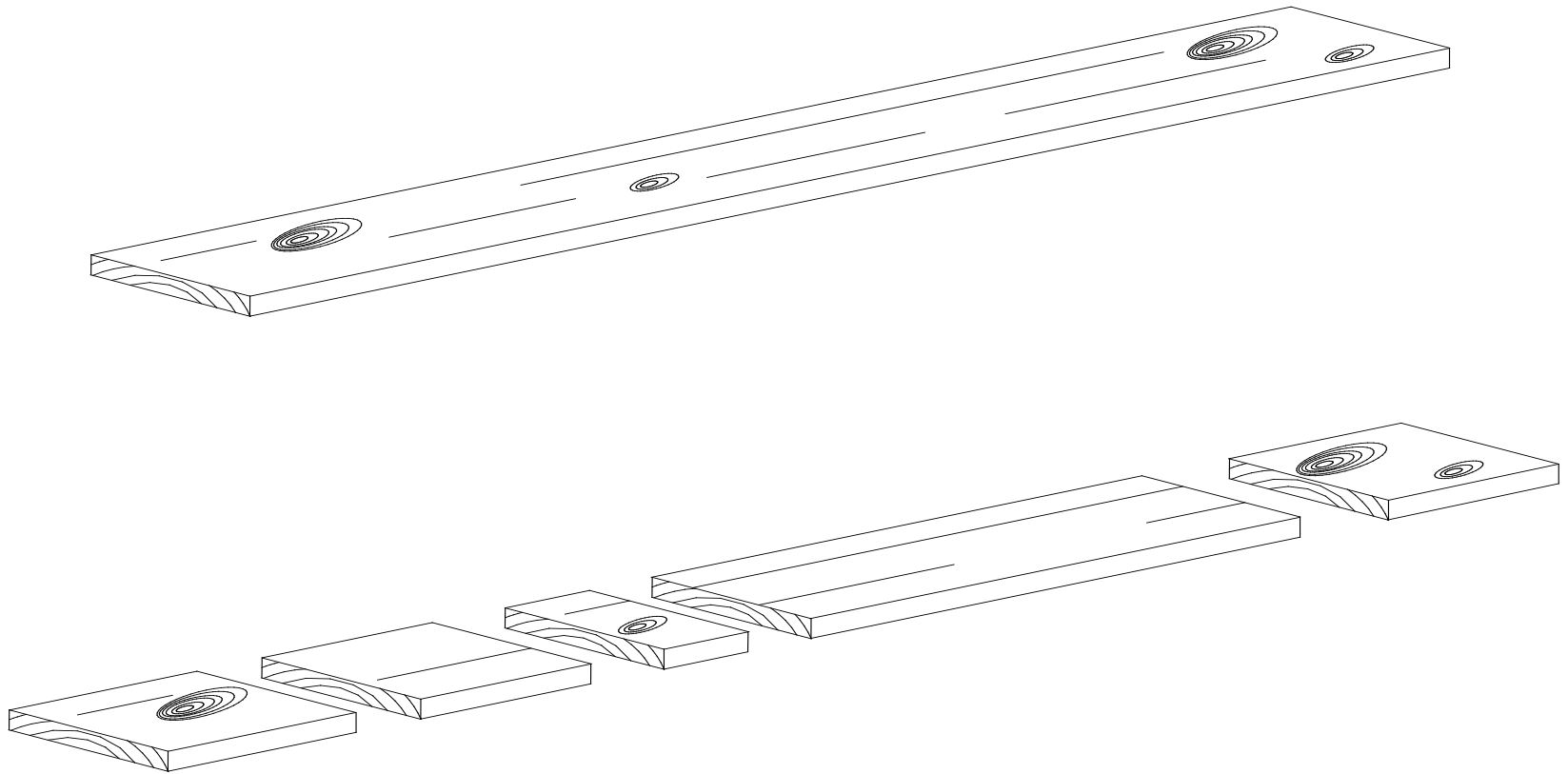

Finger-Jointing

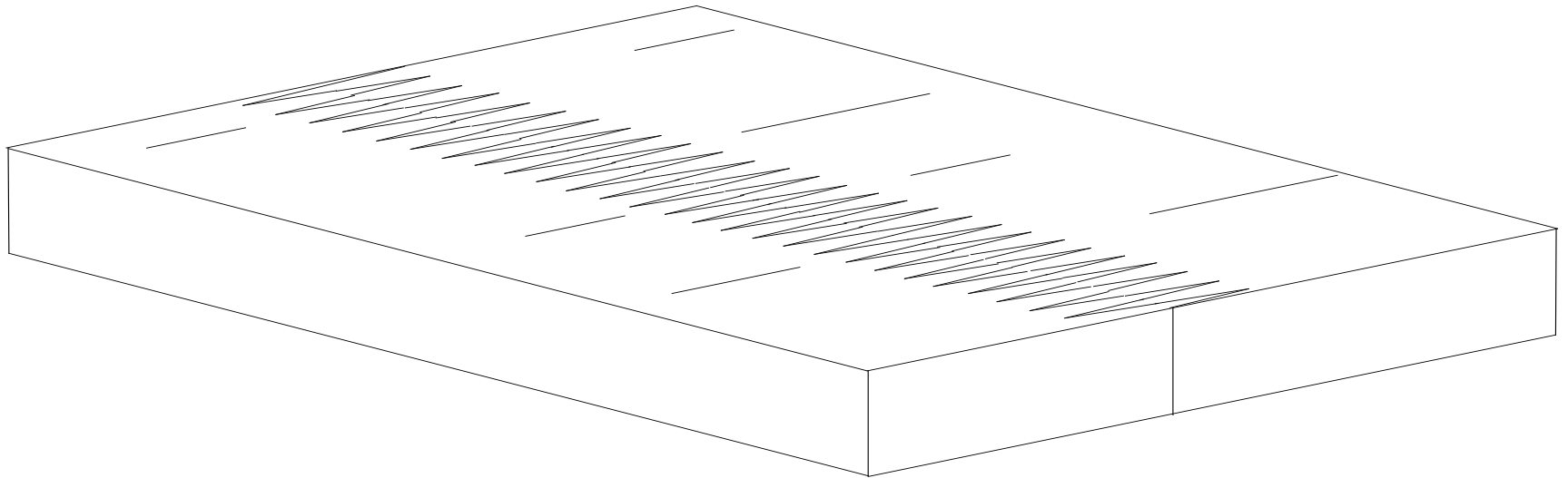

Corsican pine cladding

- Excellent treatability of Corsican pine
- Potential to defect cut and finger joint
- Modify existing supply chain
- Product range – basic boards to factory finished systems

Specialist equipment

- Defect cutting saw (£15k - manual feed)
- Finger jointer (finger jointer £30k, joint press £27k, glue spray - manual £2.5k)

Summary: cladding

	Tree	Roundwood	Process	Product
£/m ³	5	35	250	300
Capital/£			75k	
People			+5	