

# Windows

# JOINERY - WINDOWS – HARDWOOD e.g OAK & SWEET CHESTNUT

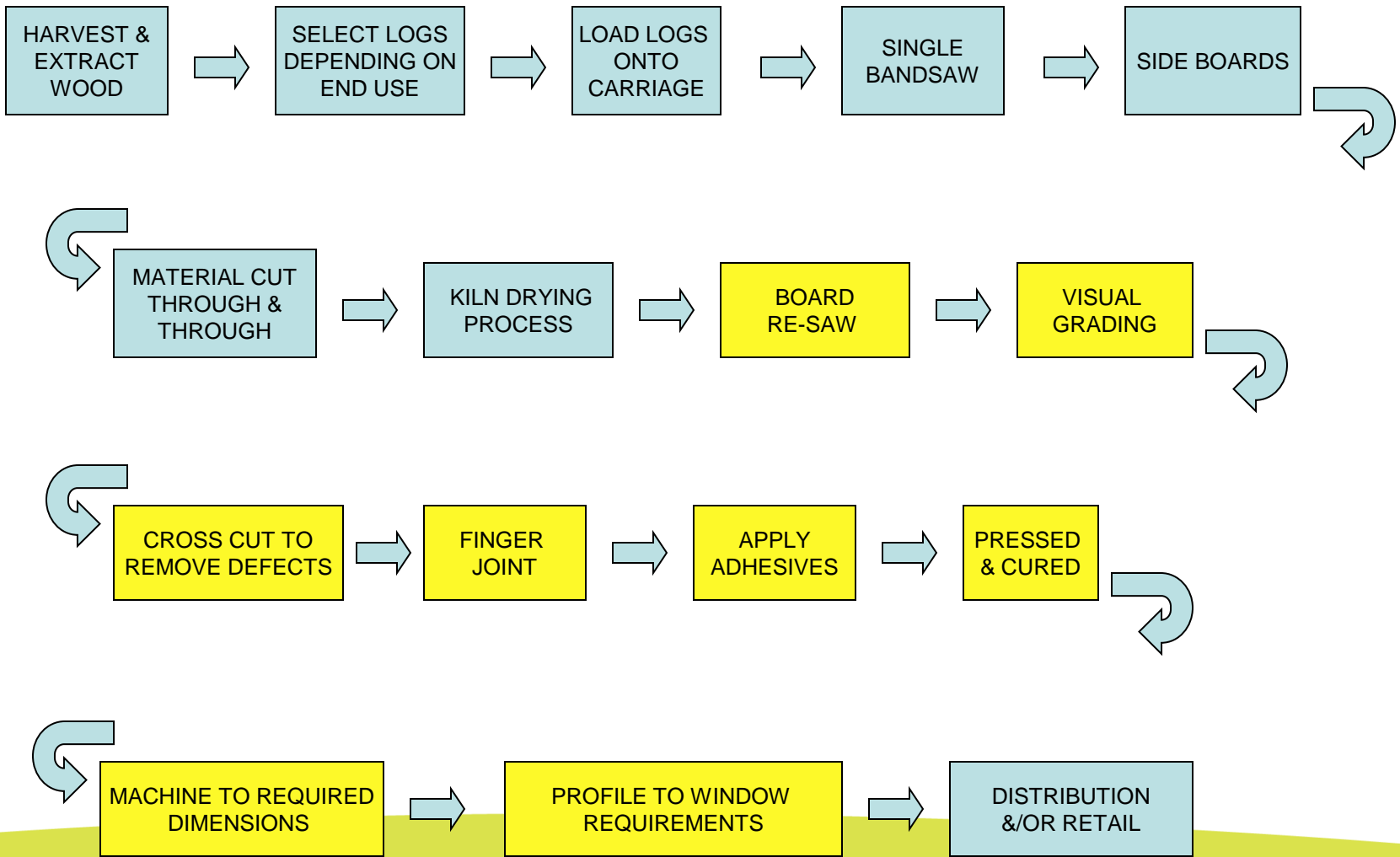

# Sweet Chestnut coppice



# Defect Removal

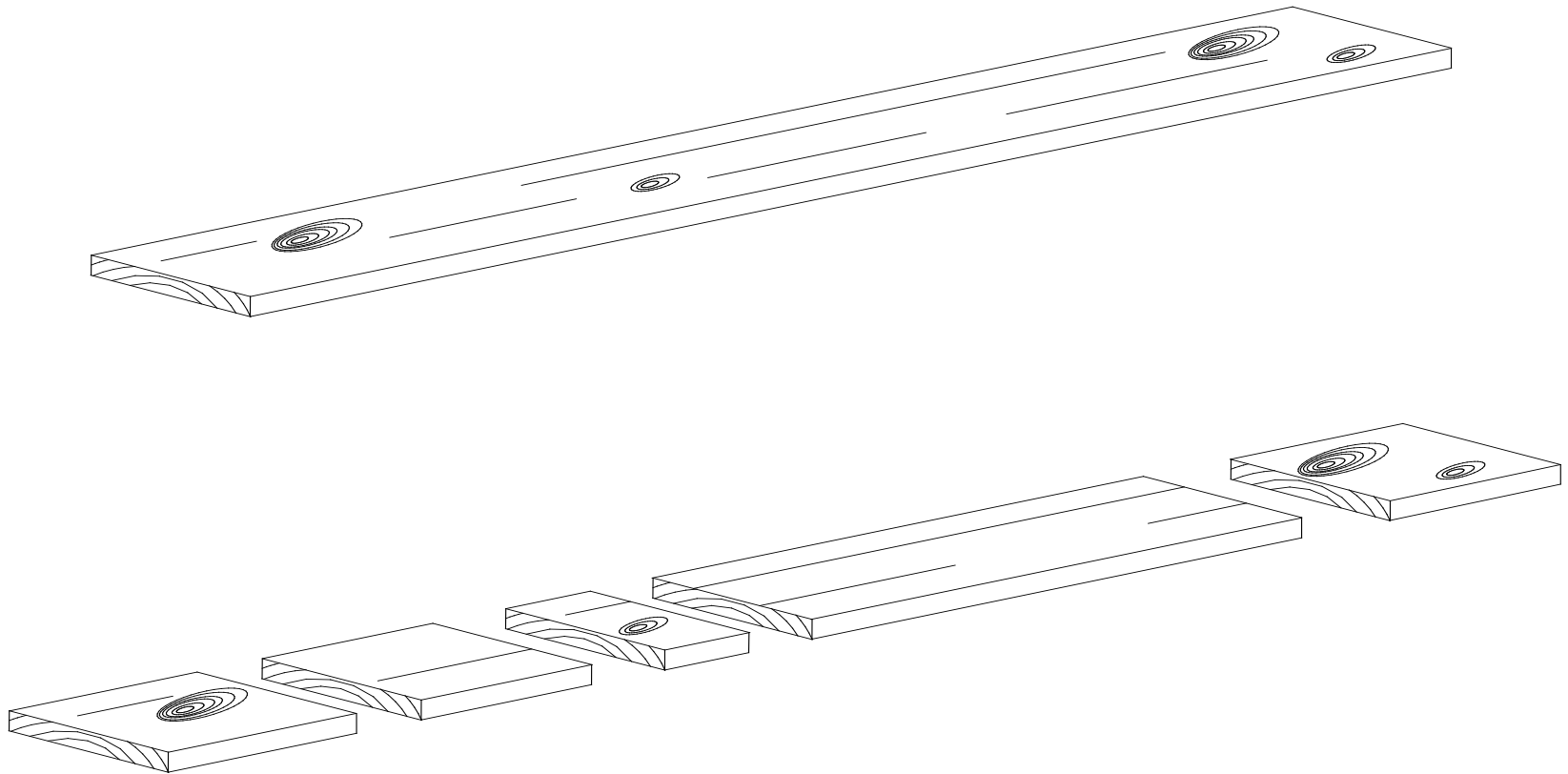

# Defect cutting

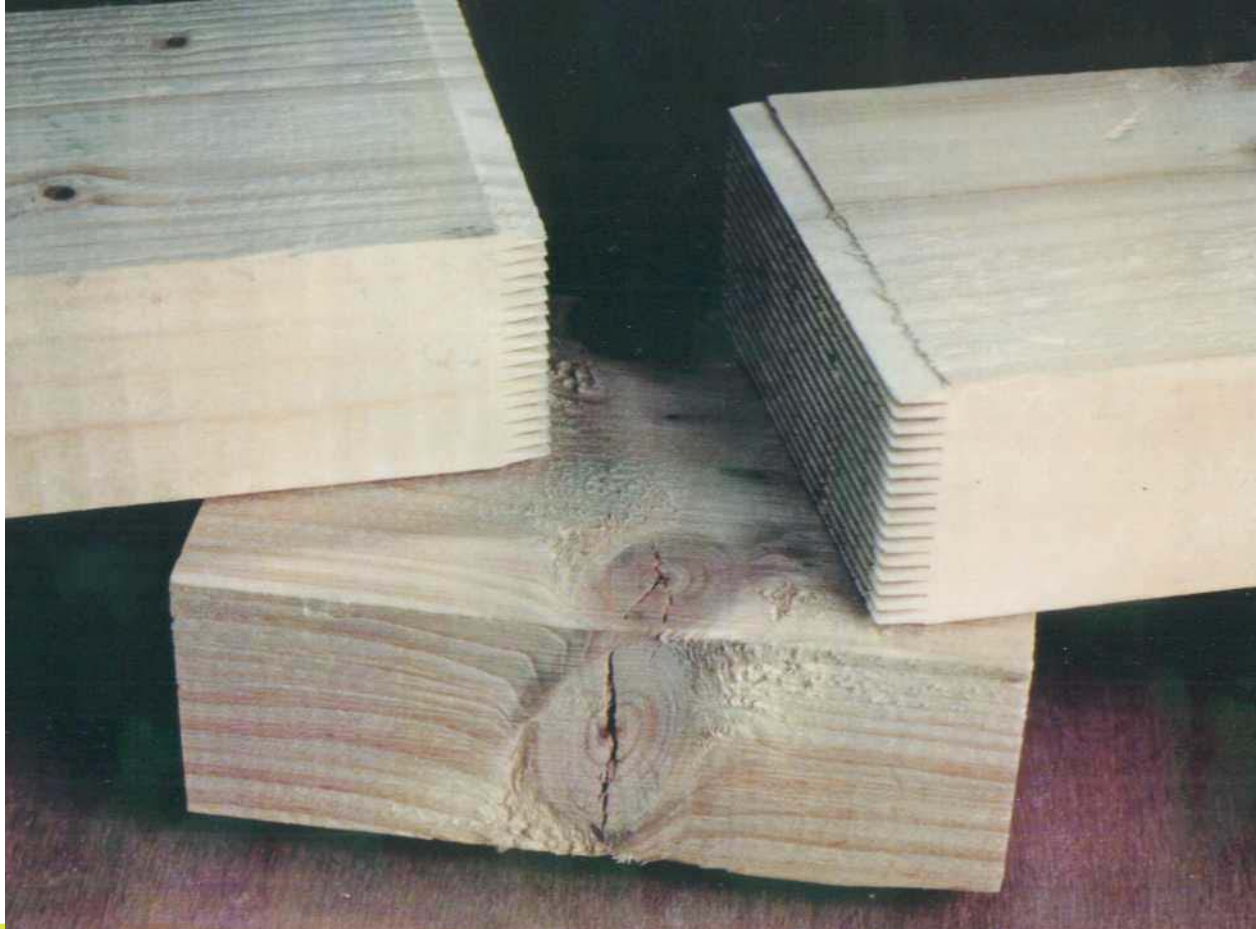

# Finger-joint & Face Laminate

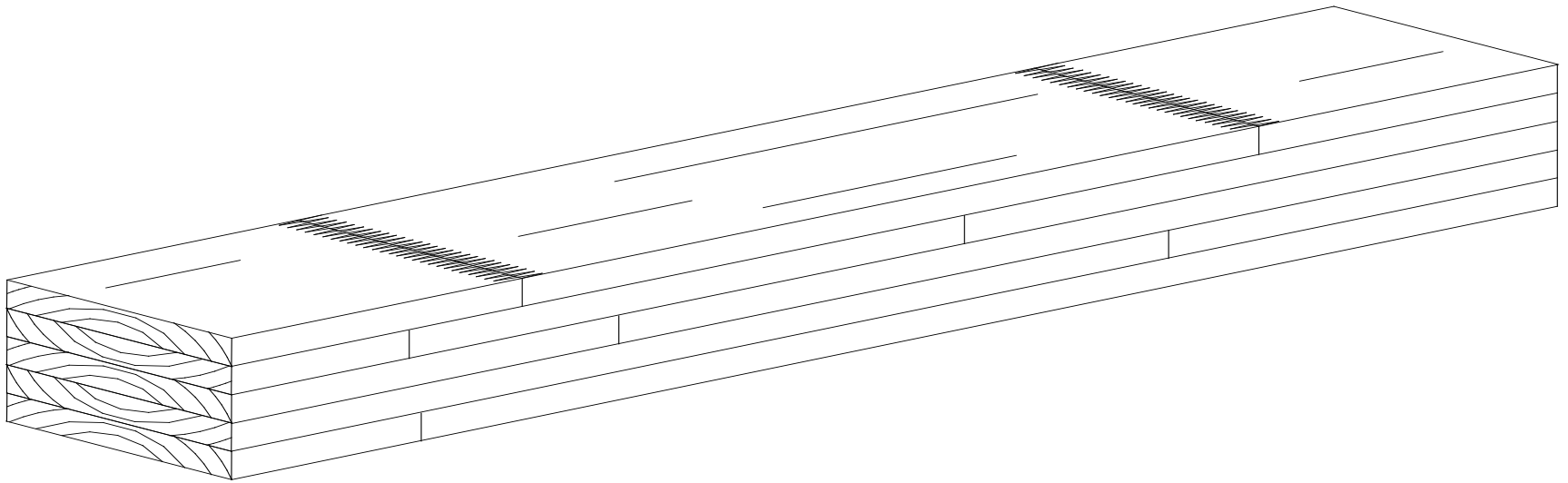

# Window laminate



# Finger jointed and laminated oak window



# Re-engineered windows

- Use of low value hardwood feed stock
- Improved dimensional stability
- Improved coating performance
- Potential to green glue leading to process efficiencies
- Enhanced management of hardwood woodlands

# Specialist equipment

- Scanner (£60k)
- Defect cutting saw (£15k - manual feed)
- Finger jointer (finger jointer £30k, joint press £27k, glue spray - manual £2.5k)
- Laminating press (£10k - manual)

# Summary: Windows

	Tree	Roundwood	Process	Product
£/m <sup>3</sup>	5	35	250	9000
Capital/£			145k	
People			+10	